

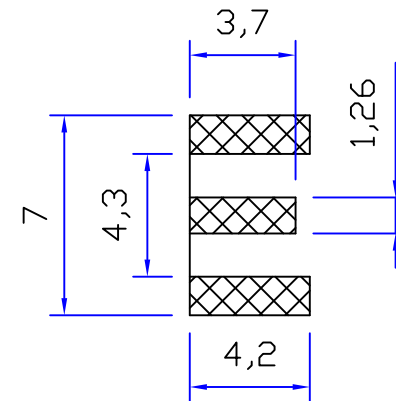

Product NO.		RHT-612-0202			
REV	DESCRIPTION	DWN	DATE	APPROVEN	
A	First issue	SAM	2016/06/07	JIM. KING	

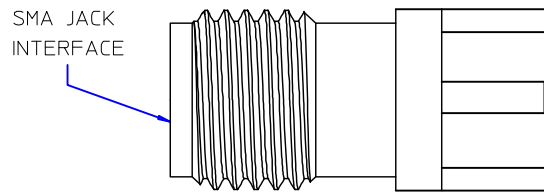
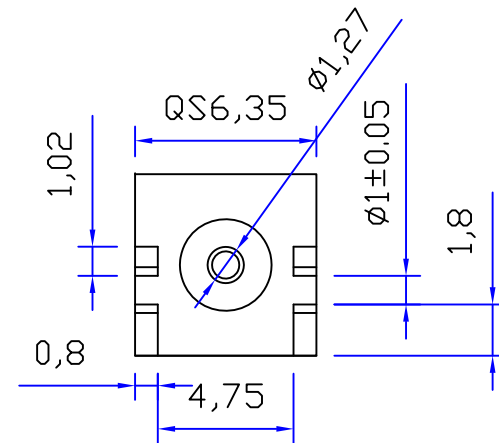
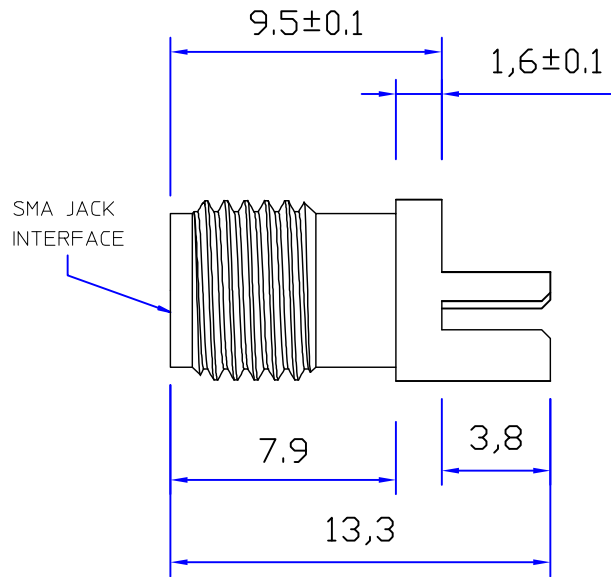

RECOMMENDED MOUNTING PAD

BASE WIDTH: 6,35
 BOARD THICKNESS: 0,81
 BOARD MATERIAL: FR4 W/28 g(1.0 OZ) COPPER
 ON BOTTOM (GROUND) SIDE

-TOLERANCES- UNLESS OTHERWISE SPECIFIED		RENHOTEC GROUP						
		Title: SMA JACK CONNECTOR						
0. ±10	0.° ±30°	Appd:	P/N: RHT-612-0202					
0.0 ±0.05	0.0° ±25°	Check:	Xiong Tan	Date	Scale	Unit	Type	Page
0.00±0.03	0.00° ±2.0°	Draw.:	Owen	2016.06.07	Free	MM	Z	1/1

1	Body	Brass	GOLD:1-1.5U"
2	Insulator	TEFLON	White
3	Center contact	Phosphor	GOLD:3u"
NO	Component Number	Material	Finish